

COMPACT TENSIONED



- Silent motor system provides a smooth and quiet operation
- Totally manufactured in aluminium
- Smart design and easy to install
- Housing dimensions: 94x112 mm.
- Painting treatment with white epoxy powders (RAL 9010)
- Universal mounting brackets either for ceiling or for wall
- Switcher on/off included
- Projection fabrics are flame-retardant, classification M1 7201-96
- Side black borders of 5 cm. (in the narrowest point), black drop of 30 cm. on the top and black counterweight (35 mm. high)
- Tensioning system on both sides
- Two mounting brackets included

Warranty: - 5 years on the motor
 - 24 months on the other components

TECHNICAL DETAILS

Format 4:3 Viewing area (wxh) (A)	Format 16:9 Viewing area (wxh) (A)	Overall dimensions	Front projection cloths	Net weight approx.
cm. 160x120 cm. 180x135 cm. 200x150 cm. 250x190	cm. 160x 90 cm. 180x101 cm. 200x112 cm. 250x140	B cm. 198 C cm. 192 B cm. 218 C cm. 212 B cm. 238 C cm. 232 B cm. 288 C cm. 282	Matte White gain 1.2 Microperforated gain 1.1 Lumi-Grey gain 0.8	Kg. 17 Kg. 18 Kg. 19 Kg. 20

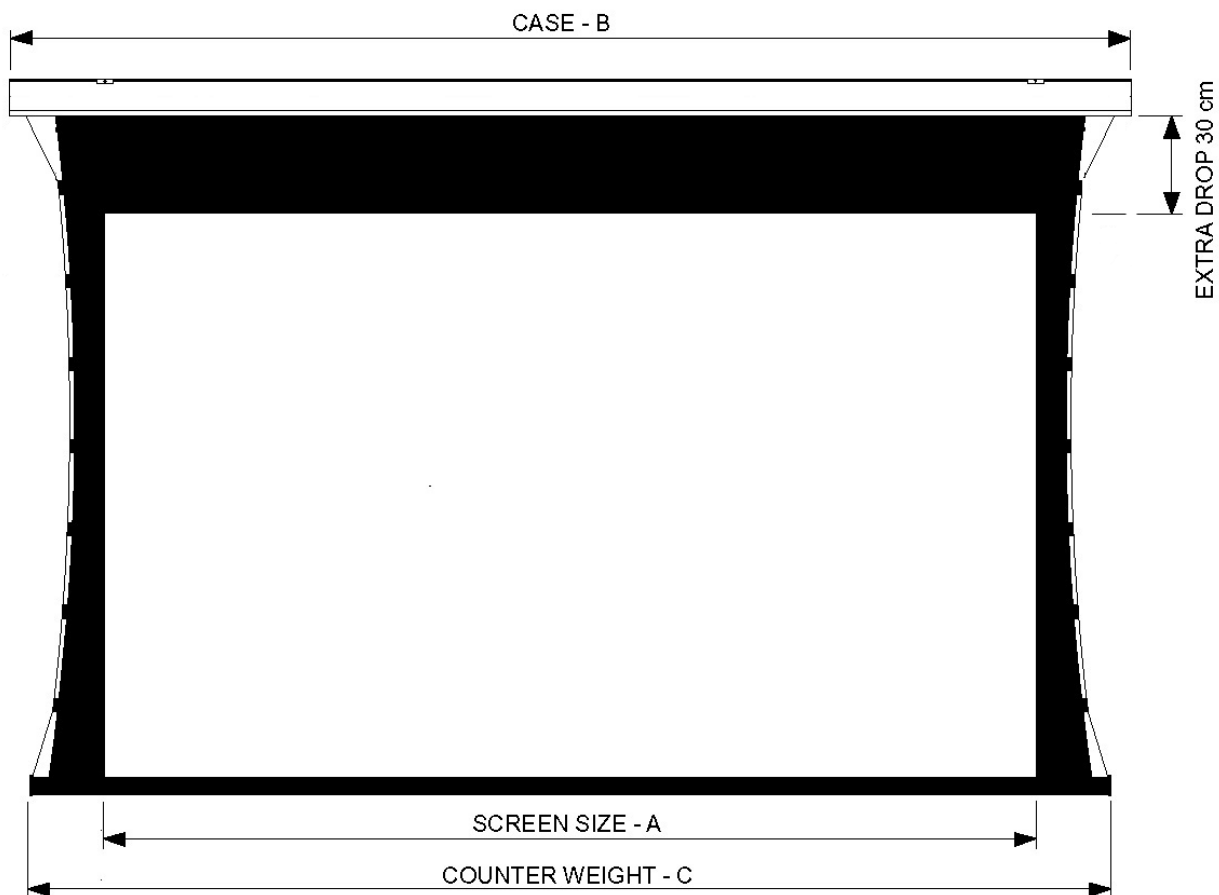

Concealing counterweight

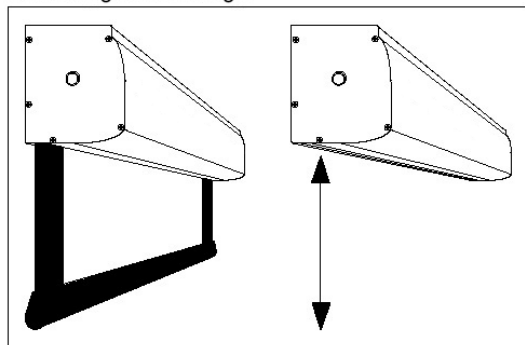

Wall Mounting

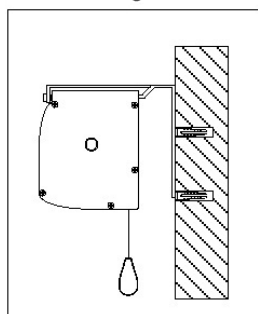

Cabinet dimensions

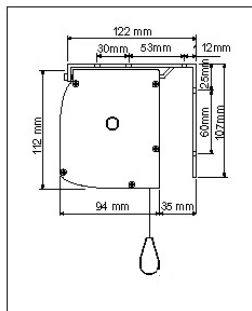

Ceiling Mounting

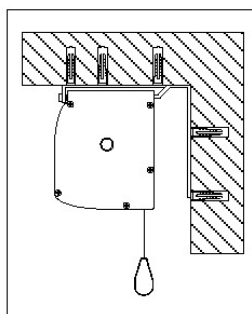

Motor characteristics

Power: 6 Nm
 Speed: 17 rpm
 Power supply: 230V / 50 Hz
 Consumption: 90 W
 Certification: IMQ

Euroscreen S.r.l. has reserved the right to modify the technical characteristics of its products, without obligation of notice and in every time, illustrated in this data sheet, in order to further improve their performance.

EUROSCREEN S.R.L.

Via Stiria, 45/16— 33100 UDINE - Tel. +39 0432 522755 Fax +39 0432 524000

Website: www.screenint.com - E-mail: info@screenint.com